

Silicon Controlled Rectifier Series 70C

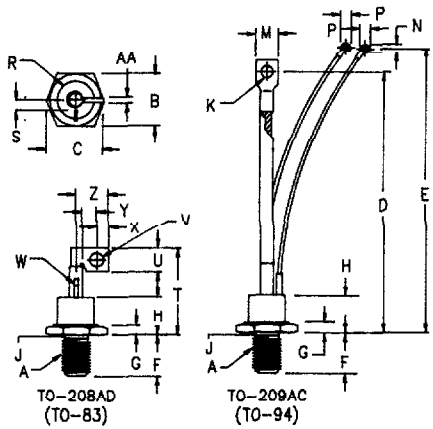

Note 1: 1/2-20 UNF-3A
 Note 2: Full thread within 2 1/2 threads
 Note 3: For insulated cathode lead,
 add suffix "IL" to catalog number

Dim.	Inches		Millimeter		Notes
	Minimum	Maximum	Minimum	Maximum	
A	---	---	---	---	1
B	1.050	1.060	26.67	26.92	
C	---	1.161	---	29.49	
D	5.850	6.144	149.10	156.06	
E	6.850	7.375	173.99	187.33	
F	.797	.827	20.24	21.01	
G	.276	.286	.701	7.26	
H	---	.948	---	24.08	
J	.425	.499	10.80	12.67	2
K	.260	.280	6.60	7.11	Dia.
M	.500	.600	12.70	15.24	
N	.140	.150	3.56	3.81	
P	---	.295	---	7.49	
R	---	.900	---	22.86	Dia.
S	.225	.275	6.48	6.99	
T	---	1.750	---	44.45	
U	.370	.380	9.40	9.65	
V	.213	.223	5.41	5.66	Dia.
W	.065	.075	1.65	1.91	Dia.
X	.215	.225	5.46	5.72	
Y	.290	.315	7.37	8.00	
Z	.514	.530	13.06	13.46	
AA	.089	.099	2.26	2.51	

Microsemi Catalog Number	Forward & Reverse Repetitive Blocking	Reverse Transient Blocking
Standard Lead	Flag Lead	
70C60B	70C60BF	600
70C80B	70C80BF	800
70C100B	70C100BF	1000
70C120B	70C120BF	1200

To specify dv/dt other than 200V/usec., contact factory.

- High dv/dt—200 V/usec.
- 1200 Amperes surge current
- Low forward on-state voltage
- Package conforming to either TO-209AC or TO-208AD outline
- Economical for general purpose phase control applications



Electrical Characteristics

Max. RMS on-state current	$I_{T(RMS)}$ 86 Amps	$T_C = 70^\circ C$
Max. average on-state cur.	$I_{T(AV)}$ 55 Amps	$T_C = 70^\circ C$
Max. peak on-state voltage	V_{TM} 1.4 Volts	$I_{TM} = 220 A(\text{peak})$
Max. holding current	I_H 200 mA	
Max. peak one cycle surge current	I_{TSM} 1200 A	$T_C = 70^\circ C, 60\text{Hz}$
Max. I_{2t} capability for fusing	I_{2t} 6000A ² S	$t = 8.3 \text{ ms}$

Thermal and Mechanical Characteristics

Operating junction temp range	T_J	-40°C to 125°C
Storage temperature range	T_{STG}	-40°C to 150°C
Maximum thermal resistance	$R_{\theta JC}$	0.32°C/W Junction to case
Typical thermal resistance	$R_{\theta CS}$	0.20°C/W Case to sink
Max mounting torque		130 inch pounds maximum
Weight		70C-B Approx. 3.6 ounces (102.0 grams) typical 70C-BF Approx. 3.24 ounces (91.8 grams) typical

PH: 303-469-2161
 FAX: 303-466-3775

Microsemi Corp.
Colorado

70C

Switching			
Critical rate of rise of on-state current (note 1)	di/dt	100A/usec.	T _J = 125°C
Typical delay time (note 1)	t _d	3.0 usec.	T _J = 125°C
Typical circuit commutated turn-off time (note 2)	t _q	100 usec.	T _J = 125°C
Note 1: I _{TM} = 50A, V _D = V _{DRM} , V _{GT} = 12V open circuit, 20 ohm-0.1 usec. rise time Note 2: I _{TM} = 50A, di/dt = 5A/usec., V _R during turn-off interval = 50V min., reapplied dv/dt = 20V/usec., linear to rated V _{DRM} , V _{GT} = 0V			

Triggering			
Max. gate voltage to trigger	V _{GT}	3.0V	T _J = 25°C
Typical gate voltage to trigger	V _{GT}	1.0V	T _J = 25°C
Max. nontriggering gate voltage	V _{GD}	0.25V	T _J = 125°C
Max. gate current to trigger	I _{GT}	100mA	T _J = 25°C
Typical gate current to trigger	I _{GT}	48mA	T _J = 25°C
Max. peak gate power	P _{GM}	15W	
Average gate power	P _{G(AV)}	3.0W	t _p = 10 usec.
Max. peak gate current	I _{GM}	4.0A	
Max. peak gate voltage (forward)	V _{GM}	10V	
Max. peak gate voltage (reverse)	V _{GM}	5.0V	

Blocking			
Max. leakage current	I _{DRM}	10mA	T _J = 125°C & V _{DRM}
Max. reverse leakage	I _{RRM}	10mA	T _J = 125°C & V _{RRM}
Critical rate of rise of off-state voltage	dv/dt	200V/usec.	T _J = 125°C

70C

Figure 1
Typical Forward On-State Characteristics

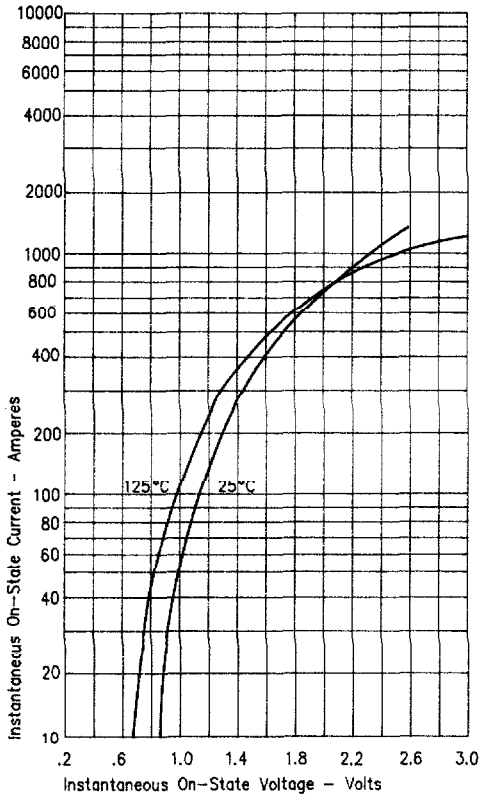

Figure 3
Maximum Power Dissipation

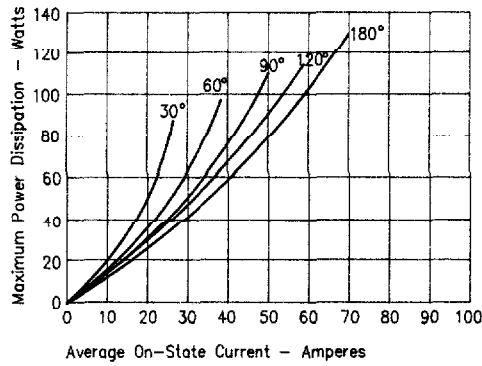

Figure 4
Transient Thermal Impedance

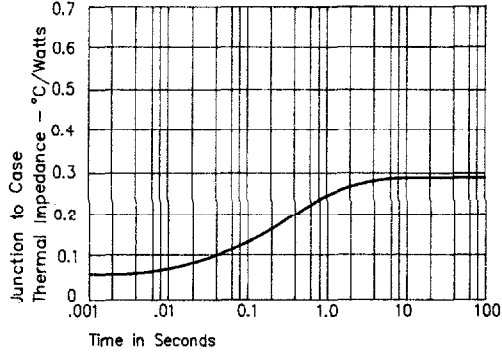

Figure 2
Forward Current Derating

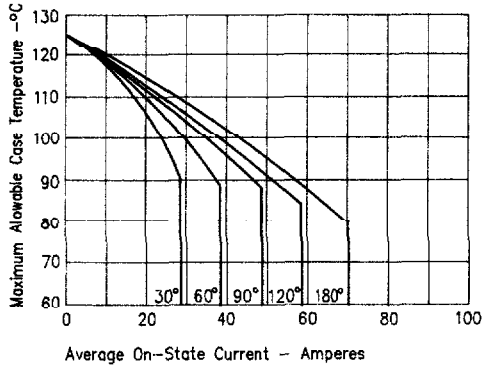
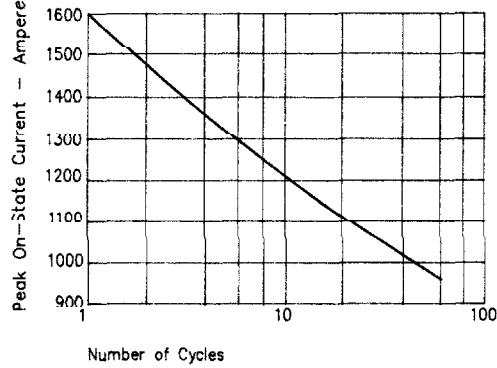

Figure 5
Maximum Nonrepetitive Surge Current



F